

Overall mass transfer between electrodes and normal impinging submerged multijets of electrolyte

J. NANZER*, A. DONIZEAU, F. COEURET

CNRS, Ecole Nationale Supérieure de Chimie, Avenue de Général Leclerc, 35000 Rennes-Beaulieu, France

Received 7 February 1983

The overall mass transfer between submerged circular multijets of electrolyte and flat circular electrodes normal to the jets is experimentally investigated. The jets are arranged according to square networks. The jet height, the jet diameter, the number of the jets constituting the multijets, the velocity of the jet and the electrode diameter are the parameters of this study which proposes an empirical correlation for one electrode, the diameter of which corresponds to the maximum diameter of the circular area impinged by the multijets.

1. Introduction

In the literature several papers are devoted to heat or mass transfer between a flat surface and a jet of fluid impinging perpendicularly on it; among these [1-9] are probably the most representative. Only a few authors used the electrochemical method for the determination of local or global mass transfer coefficients between one jet of liquid issued from a circular injector and a surface normal to the jet axis [1, 2, 7-9]. The influence of various parameters (exit jet velocity, jet height, dimension of the transfer surface) was studied and generally lead to correlations having a theoretical basis for the case of laminar jets [7, 8] but being only empirical for turbulent jets.

Wall to liquid mass transfer coefficients corresponding to the normal impingement of a jet are necessarily high because in the zone of impact the liquid velocity vector has principally a component normal to the transfer surface, at least when the jet length is not too important. The use of impinging jets of electrolyte on one electrode may be an interesting means of improving the space-time yield of electrochemical cells, considering that the increase of the space-time yield is obtained by increasing k/Q , the ratio of the overall mass transfer coefficient, k , to the volumetric flow rate, Q , of electrolyte. However, only the multijets may make possible high specific productivities and

allow pseudo-uniform distributions of the local mass transfer coefficients over electrodes having large dimensions. Thus, multijets have to be considered as having a potential applicability in applied electrochemistry. The work of Tvarusko [11] considered the idea of a set of jets, but only for metal deposition.

Almost all the papers concerned with multijets were dedicated to heat transfer [12-18], probably because the drying of paper is a frequent application. Only [6] seem to consider mass transfer although the electrochemical technique was recently applied to mass transfer studies between submerged multijets and concentric rings [19]. Generally the multijets are constituted by circular jets arranged according to a square or a triangular network. Unlike single jets which are generally issued from injectors long enough to present established hydrodynamic regimes at their exit, multijets are formed from distributors only some millimetres thick [13]. Empirical correlations are deduced and the influence of various parameters is established; one of the main parameters is certainly the fractional perforated area of the distributors because it determines the mutual influence of the jets and, therefore, the value of the overall mass transfer coefficient.

The aim of the present experimental work was to investigate the influence of several parameters (jet height, diameter of the holes of the distri-

*Present address: Facultad de Ingenieria Quimica UNL, 300 Santa Fe, Republic of Argentina.

butors, perforated area, etc. . .) on the overall mass transfer between submerged multijets and circular plane surfaces of different sizes, normal to the jets.

2. Experimental detail

2.1. Cell and hydraulic circuit

The cell is made of altuglas. It is a cylindrical vessel (Fig. 1); the lower cover of this vessel supports the cathodes while the upper cover serves as a guide for a cylinder of I.D. 7 cm having a total height of 26 cm. The outer surface of this cylinder is threaded so as to allow vertical movement along the cell axis; its lower extremity forms the distributors of the multijets which consist of perforated circular discs of altuglas. Finally, a large perforated circular disc can be moved around the above mentioned cylinder and along the inner wall of the

cell; it serves to guarantee the vertical position of the distributing cylinder along the cell axis.

The electrolyte comes from a circuit including a pump, two rotameters and a tank; it enters the cell at the top and is discharged through a lateral tube. Thus the cell is always full of liquid (submerged jets). The electrolyte flows in a closed circuit and its temperature is maintained at 30°C by regulation within the tank where nitrogen is continuously bubbled.

2.2. Electrodes and electrochemical method

The anode is a knit of nickel wire, with a total surface of about 2000 cm², situated within the distributing cylinder just before the perforated distributor (Fig. 1); it serves also to ensure a uniform velocity profile above the holes.

The cathodes are circular discs of copper,

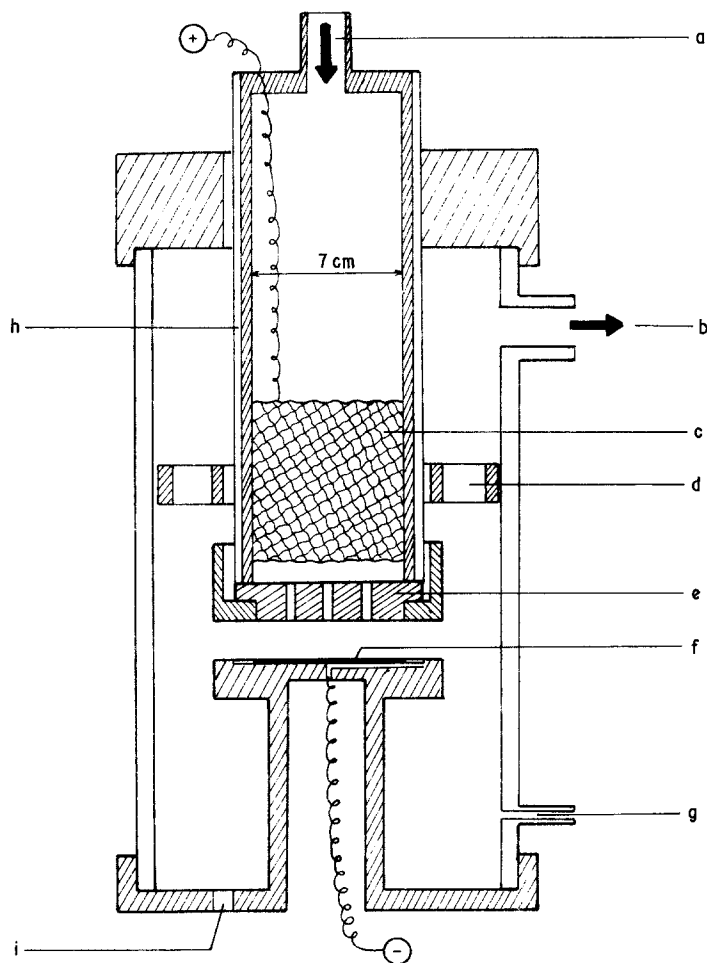

Fig. 1. Schematic view of the cell. (a) electrolyte inlet; (b) electrolyte out let; (c) extended surface anode; (d) perforated disc; (e) distributor; (f) circular cathode; (g) tube for the connection of the reference electrode; (h) cylinder axially movable; (i) drain.

formed on sheets for printed circuits, and successively electrochemically gold and platinum plated. Eight electrodes, named from S1 to S8 were prepared, with the following dimensions:

Electrode	S1	S2	S3	S4	S5	S6	S7	S8
Diameter	1.0	2.0	3.0	4.15	5.15	6.0	7.0	9.0
2 R (cm)								

The electrical wire connected to each cathode (through a small lateral piece of copper of the printed circuit) leaves the cell through its lower part.

The reaction used for the determination of the overall mass transfer coefficient \bar{k} at the cathode is the reduction of potassium ferricyanide ions. The electrolyte is a solution of 0.5 mol dm⁻³ sodium hydroxide supporting a mixture of potassium ferricyanide (0.005 mol dm⁻³) and of potassium ferrocyanide (0.05 mol dm⁻³); the true ferricyanide concentration is known by amperometric titration with cobalt sulphate on a rotating disc electrode. The physico-chemical properties of the electrolyte at 30° C are: the specific gravity, $\rho = 1.05 \text{ g cm}^{-3}$, $\nu = 0.94 \times 10^{-2} \text{ cm}^2 \text{ s}^{-1}$ for the kinematic viscosity, $D = 8.8 \times 10^{-6} \text{ cm}^2 \text{ s}^{-1}$ for the diffusivity of ferricyanide ions and thus $Sc = 1070$ for the Schmidt number.

The placement of the anode before the cathode in the hydraulic circuit does not alter the bulk ferricyanide concentration which will also determine the mass transfer coefficient.

2.3. Distributors

Table 1 shows the diagram of a distributor and summarizes the characteristics of all the distributors used. Each distributor is made of altuglas; it is 2 cm thick and the diameter of the surface area free for perforations is 7 cm. The characteristics given in Table 1 have the following meaning: d is the diameter of the cylindrical hole or injector, X is the distance between the centres of two neighbouring holes, N is the number of holes, and A_f is the degree of perforation of the distributor or fraction of the distributor area which is occupied by holes.

All the holes are made according to a square network, the diameter, d , being varied between 0.15 cm and 1.0 cm and the relation between X/d and A_f being the following:

$$X/d = 0.714(A_f)^{-1/2} \tag{1}$$

Fifteen distributors (named from P1 to P15) have been made (see Table 1) thus allowing A_f to be variable between 0.5% and 8.2%. The distance, H , between the distributor and the cathode, i.e. the jet height, is measured by means of a cathetometer.

3. Results and comments on the results

3.1. Influence of the height, H , of the jets

The influence of H on the overall mass transfer coefficient \bar{k} has been investigated with electrode

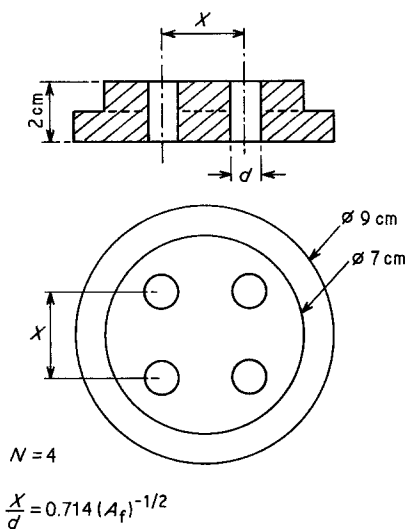

Table 1. Characteristics of different distributors

Distributor	d (cm)	X (cm)	N	A_f (%)
P1	0.15	0.83	36	1.65
P2	0.18	1.0	25	1.65
P3	0.18	0.83	36	2.40
P4	0.20	1.0	25	2.04
P5	0.25	2.5	4	0.50
P6	0.25	1.66	9	1.15
P7	0.25	1.25	16	2.04
P8	0.25	1.0	25	3.2
P9	0.25	0.83	36	4.6
P10	0.33	1.66	9	2.04
P11	0.35	1.66	9	2.25
P12	0.40	1.66	9	2.94
P13	0.45	1.66	9	3.72
P14	0.50	2.5	4	2.04
P15	1.0	2.5	4	8.16

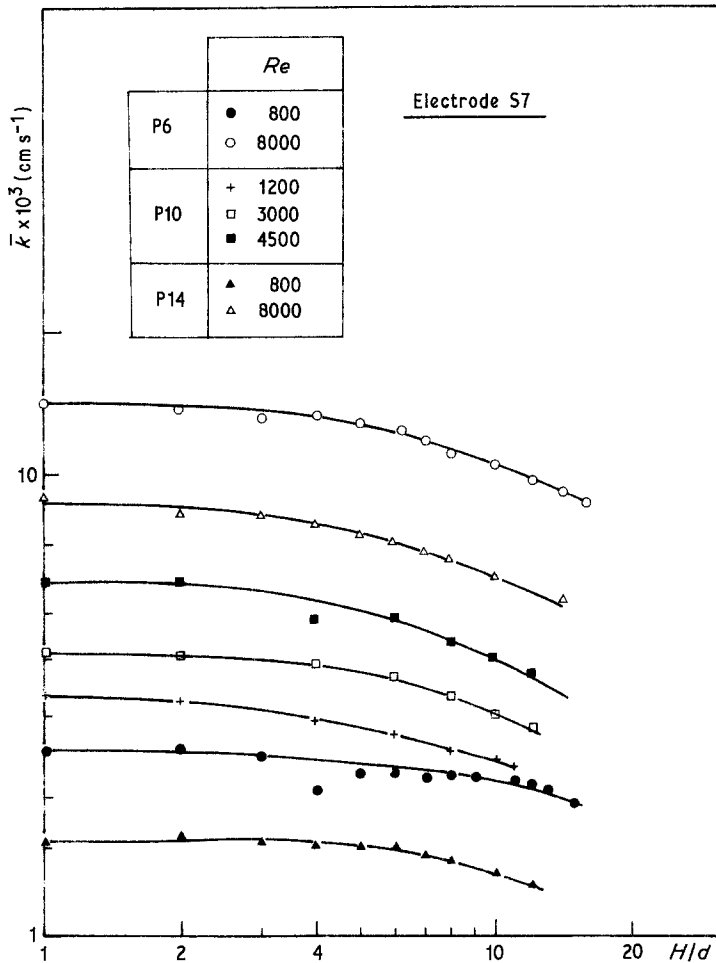

Fig. 2. Influence of the relative height H/d of the jets on the overall mass transfer coefficient.

S7 and distributors P5, P6, P10, P14; the values adopted for the injection Reynolds number, $Re = \bar{u}d/\nu$ (\bar{u} being the mean jet velocity at the exit of the nozzle) were 800 and 8000 for distributors P6 and P14 and 1200; 3000 and 4500 for distributors P5 and P10. As in [2], the ratio H/d has been taken as a characteristic dimensionless number, according to a dimensional analysis of the problem.

The results obtained with distributors P6, P10 and P14 are given in Fig. 2. They show that \bar{k} is nearly independent of H/d in the range $6 < H/d < 8$ whatever the hydrodynamic regime within the holes of the distributors; let us recall that the height of the cone in which the axial velocity of the liquid jet is equal to the velocity at the nozzle, is about $6d$ up to $8d$ [2]. When H/d is higher than 6 or 8, \bar{k} decreases rapidly when H/d is increased. as can be observed for single jets [2]. Also as in [2], the decrease of \bar{k} begins to be

noticeable for values of H/d which are smaller when Re is increased.

The quasi independence of \bar{k} with respect to H/d when $H/d < 6$ is in agreement with other results obtained for multijets [12, 14, 15, 18]. Otherwise, Chance [18] indicated that the decrease of \bar{k} when H/d is increased, seems to be the more pronounced when A_f is high; also such a comment can be made from Fig. 2. Thus, low values of H/d seem to be preferable when high degrees of perforation are employed. The results obtained do not agree with those deduced from heat transfer [13]; these indicate, paradoxically, an increase of \bar{k} with H/d .

The decrease of \bar{k} for high values of H/d may be explained by the decrease of the jet impinging velocity after $H/d = 6$. Also the interacting zones between jets changes with H/d , in a manner probably more pronounced in a turbulent regime than in a laminar regime.

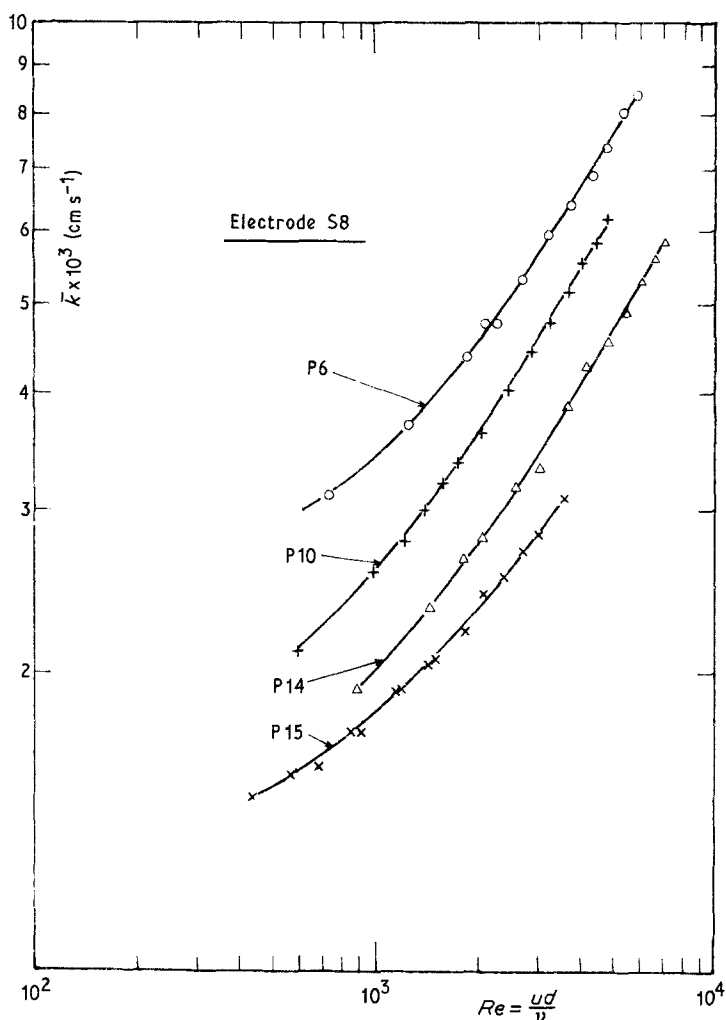

Fig. 3. Influence of the Reynolds number at the nozzles on the value of \bar{k} .

3.2. Influence of the jet Reynolds number

Owing to the above results, H/d has been maintained equal to 4, a value which also avoids the confinement of gas between the distributor and the transfer surface. As before, the cathode S7 has been employed, together with distributors P6, P10, P14 and P15.

Figure 3 shows that there is a weak change in the slope of the line representing \bar{k} against Re , in the domain $1700 < Re < 2500$ which corresponds to the transition from laminar regime to turbulent regime in the injectors. A representation of the Sherwood number, $Sh = \bar{k}d/D$, against Re gives a variation of Sh as $Re^{0.54}$ for the experimental conditions used and all the distributors except P15 which leads to $Re^{0.43}$, probably because the corresponding holes are too large ($d = 1.0$ cm) [20].

In spite of differences between their results for mass transfer in the presence of impinging multi-jets, some authors [13, 18] observe that the exponent of Re varies with A_f . Here the number of experiments does not permit the confirmation of this relationship. It seems clear here, however, that the smaller d and the distance X , the higher are the mass transfer coefficients. In other words, A_f being fixed, many thin jets form a more efficient system than a few large jets.

3.3. Influence of the parameters N , d , X , A_f of the distributors

All the experiments have been carried out with $H/d = 4$ and three values of Re (1200; 3000; 4500) were used.

Figure 4a shows the influence of d when

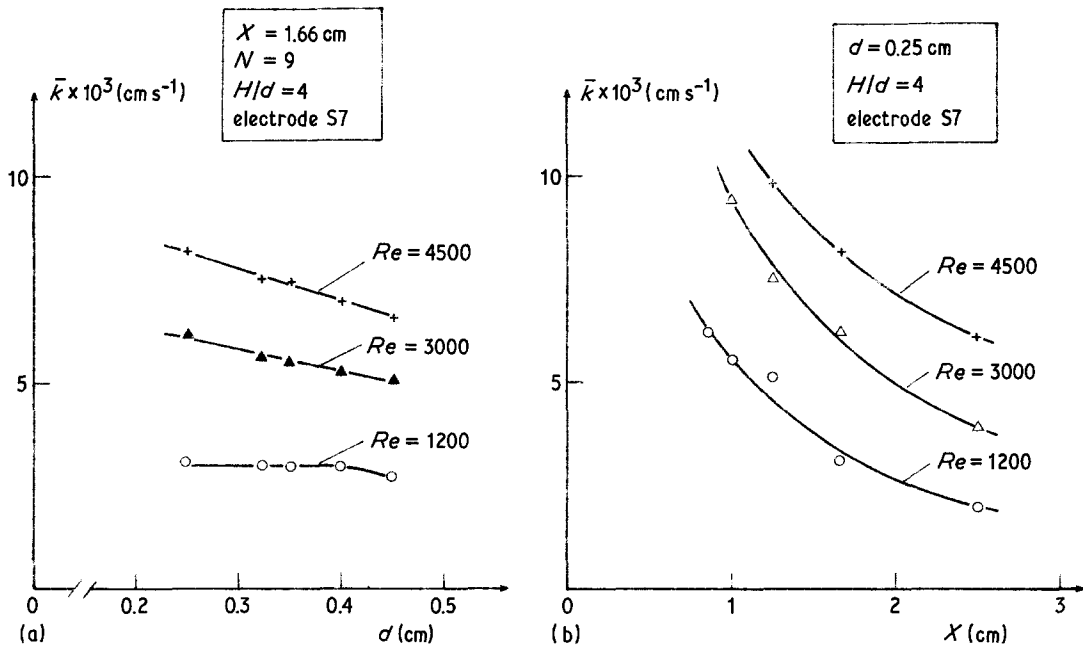

Fig. 4. Influences of the diameter d and of the distance X of the jets on the value of \bar{k} . (a) influence of d ; (b) influence of X .

$X = 1.66$ cm and $N = 9$. It can be observed that, as Re is increased, \bar{k} decreases more rapidly with an increase in d ; however, it is necessary to note that, for any given Re , an increase of d is accompanied by a decrease of the jet velocity at the nozzles. Otherwise, as indicated by Equation 1, A_f also varies with d . Except Kercher *et al.* [13] who reported a decrease of the transfer coefficient of about 10 to 15% when d is twice as low, it seems that no authors have considered the effect of d .

Figure 4b presents the influence of X when $d = 0.25$ cm. Obviously, \bar{k} increases when X is decreased, but it is also necessary to note that a decrease of X is accompanied by an improvement of N and A_f .

Figure 5 corresponds to results obtained when $A_f = 2\%$. It shows that, H/d and Re being given, \bar{k} increases when X and/or d are decreased (i.e. when N increases and when the jets are made finer). Hence it is again found that many fine jets constitute an advantageous system; as a limiting case it could be interesting to consider a porous plate distributor.

The influence of A_f is illustrated in Fig. 6, though it must be noted that A_f depends directly on X/d through Equation 1. At a given Re , \bar{k} increases with A_f , i.e. with the number, N , of jets

having a given diameter, d . The limiting case where $A_f = 100\%$ is synonymous with that of a single impinging jet having the diameter $d = 7$ cm. Calculated values for this case are indicated in Fig. 6; they are deduced from correlations in the literature [1]:

When $Re < 2000$ and $0.2 < R/d < 1$

$$Sh = \frac{\bar{k}d}{D} = 1.51Re^{1/2}Sc^{1/3}g(Sc)(H/d)^{-0.054}. \quad (2)$$

When $4000 < Re < 16000$ and $0.2 < R/d < 2$

$$Sh = \frac{\bar{k}d}{D} = 1.12Re^{1/2}Sc^{1/2}g(Sc)(H/d)^{-0.0057} \quad (3)$$

in which $g(Sc)$ is an asymptotic function of the Schmidt number, Sc , and R the radius of the electrode on which the jet is impinging.

However, as A_f was limited to a value of 4.6% the extrapolation between this value and $A_f = 100\%$ is impossible. One may only remark that the variation of \bar{k} with A_f does not seem to be in contradiction with the calculated values. The results obtained are similar to those deduced by other authors for heat transfer [13, 18] in that there is an absence of a maximal influence of A_f . Some authors observe a maximum effect of A_f near $A_f = 2\%$ or 3% but, according to Chance [18],

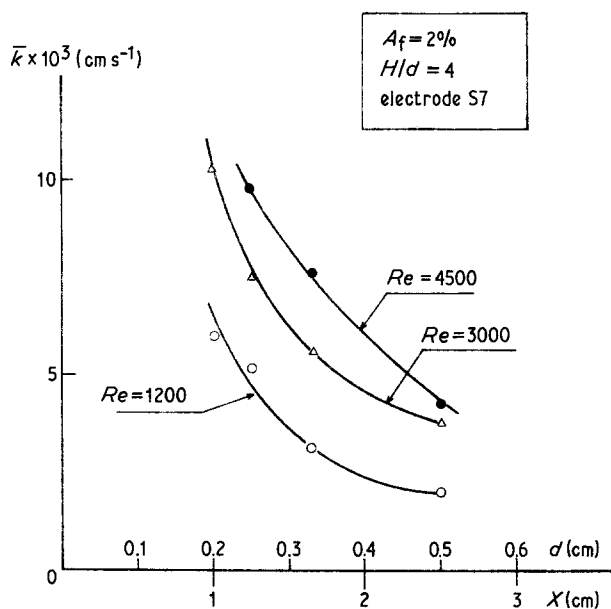

Fig. 5. Respective influence of d and of X on the value of \bar{k} , A_f being maintained constant.

such a maximum could be due to a cross-flow configuration.

3.4. Influence of the electrode diameter

The study of the influence of the electrode diam-

eter, $2R$, allows one to deduce information on the accessibility of the electrode. As previously, the values $H/d = 4$ and $Re = 1200, 1300$ and 4500 are chosen; distributors P1, P2, P3, P4, P7, P8 and P9 have been used in the experiments with various electrodes.

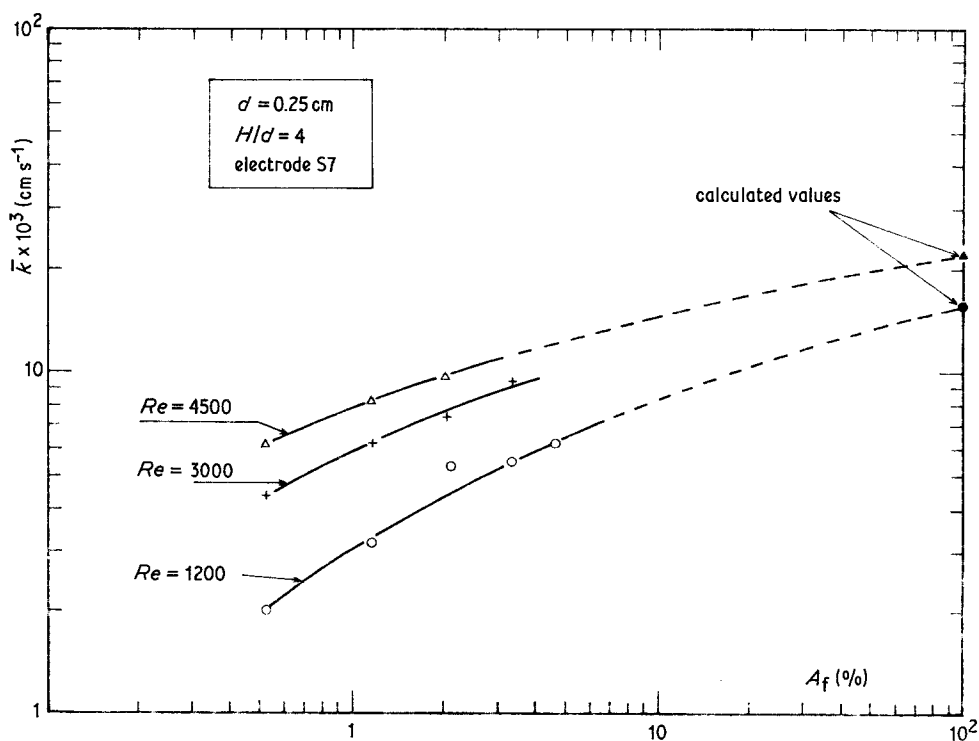

Fig. 6. Experimental variations of \bar{k} with A_f for three values of Re .

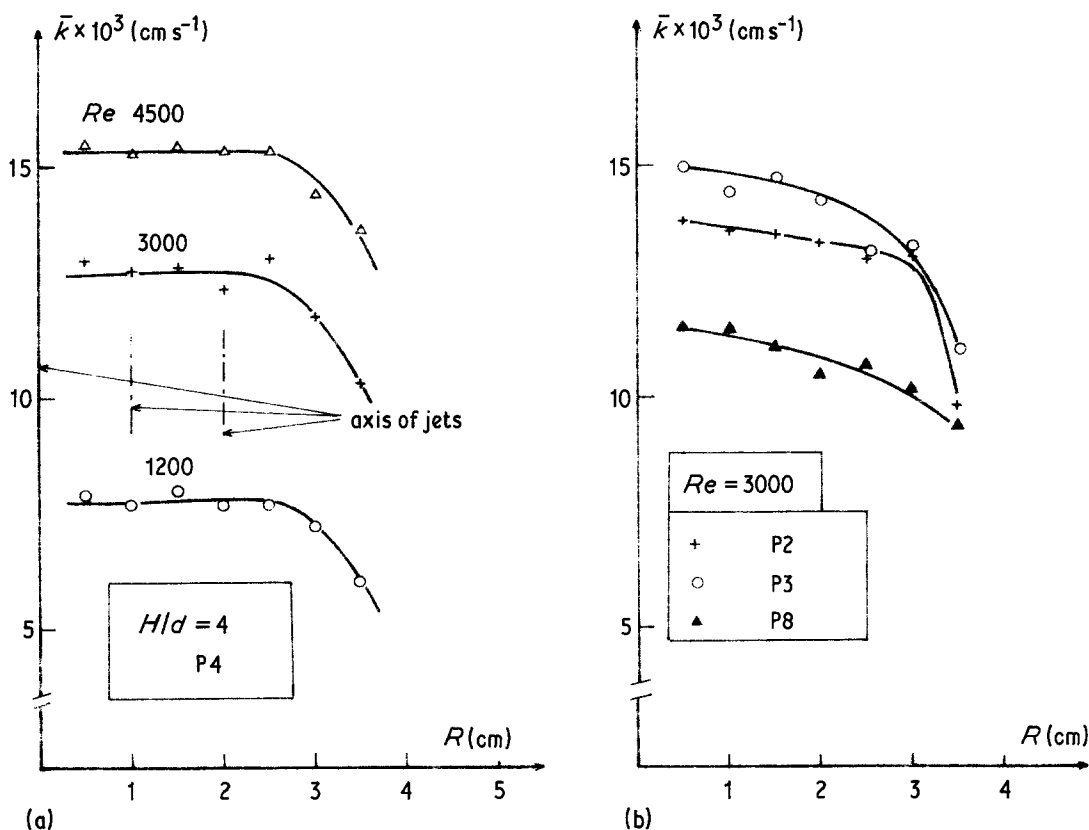

Fig. 7. Experimental variations of \bar{k} with the electrode radius R (a) influence of Re ; (b) results obtained with three different distributors.

Figure 7 gives experimental values of \bar{k} as a function of the radius R ; Fig. 7a concerns three values of Re and Fig. 7b corresponds to three distributors. One can observe in Fig. 7a that \bar{k} is nearly constant up to a radius of about 3 cm, and decreases rapidly after this value. In Fig. 7b, \bar{k} decreases progressively as R is increased up to the distance of the peripheral holes to the centre of the electrode, and then \bar{k} falls abruptly. Such a progressive decrease of \bar{k} demonstrates the fact that the electrode is not uniformly accessible. The electrode S7 used in many experiments has a diameter always larger than the diameter of the area of macro-uniformity.

4. Discussion

The analysis of the results obtained here with multijets is complex owing to the number of parameters. For the case of a single impinging jet [2], it was difficult enough to correlate the mass trans-

fer results; two empirical correlations were deduced, the first for values of H lower or equal to the height of the exit cone of the jet, the second for values of H higher than this critical height, i.e. for the domain in which \bar{k} decreases when H increases.

In the present work it appears that high values of \bar{k} correspond to H/d lower or equal to 6 to 8, i.e. to jets shorter than the height of the exit cone of the jet. Otherwise the increase of the injection Reynolds number has a positive effect on the transfer. With regards to the diameter d of the holes, it seems that it does not influence the transfer coefficient in a significant manner but d is related to X , N and A_f ; for example, the smaller X (i.e. the higher N is) for a given value of A_f , the higher is the mass transfer coefficient to the electrode.

Let us recall that the conversion of an electrolyte flowing at the volumetric flow rate, Q , through an electrochemical reactor increases

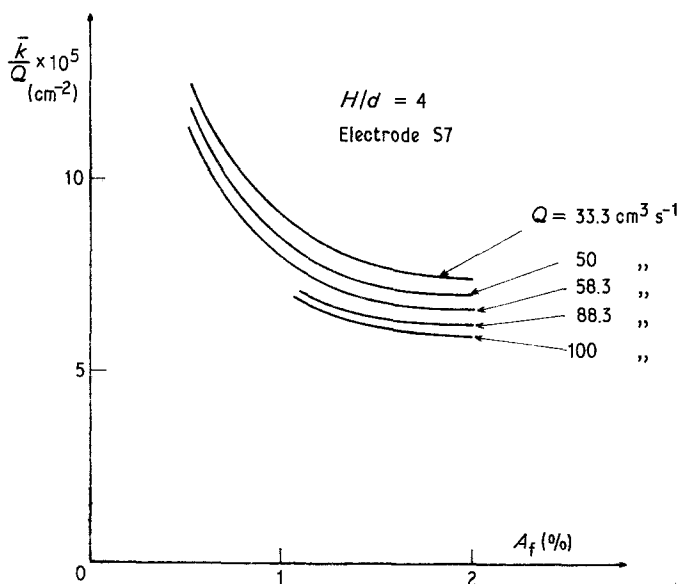

Fig. 8. Variations of \bar{k}/Q as function of A_f .

with $\bar{k}S/Q$, when the working electrode having the surface area S is operating in limiting diffusion conditions [21]; for example, for a plug-flow reactor the conversion is $[1 - \exp(-\bar{k}S/Q)]$. Thus it is interesting to find out the best hydrodynamic conditions for increasing the ratio \bar{k}/Q . Figure 8 is an example of curves deduced from the experiments; they represent the variation of \bar{k}/Q with the frac-

tional open area, A_f , for various flow rates. As A_f is increased, \bar{k}/Q first decreases rapidly and then stabilizes: otherwise, for a given A_f , the lower is Q , the higher is \bar{k}/Q . Such results suggest that a small volumetric flow rate and a small fractional open area (i.e. few holes of a given diameter) would lead to high conversions.

The results obtained with the distributor P15

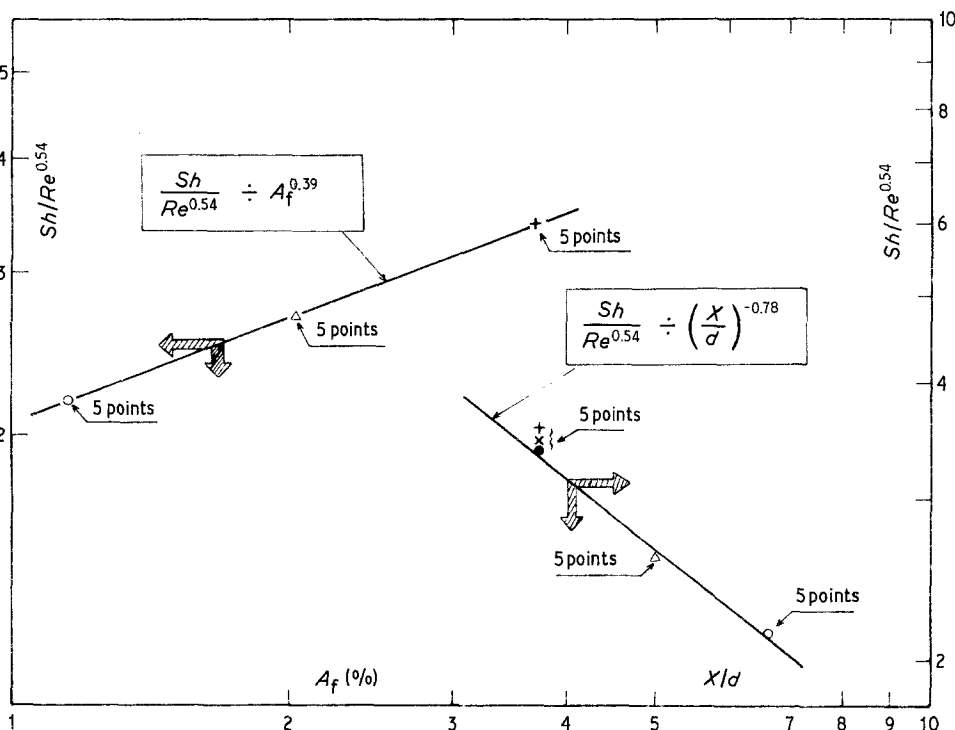

Fig. 9. Presentation of the research of the influence of X/d and of A_f in view of an empirical correlation.

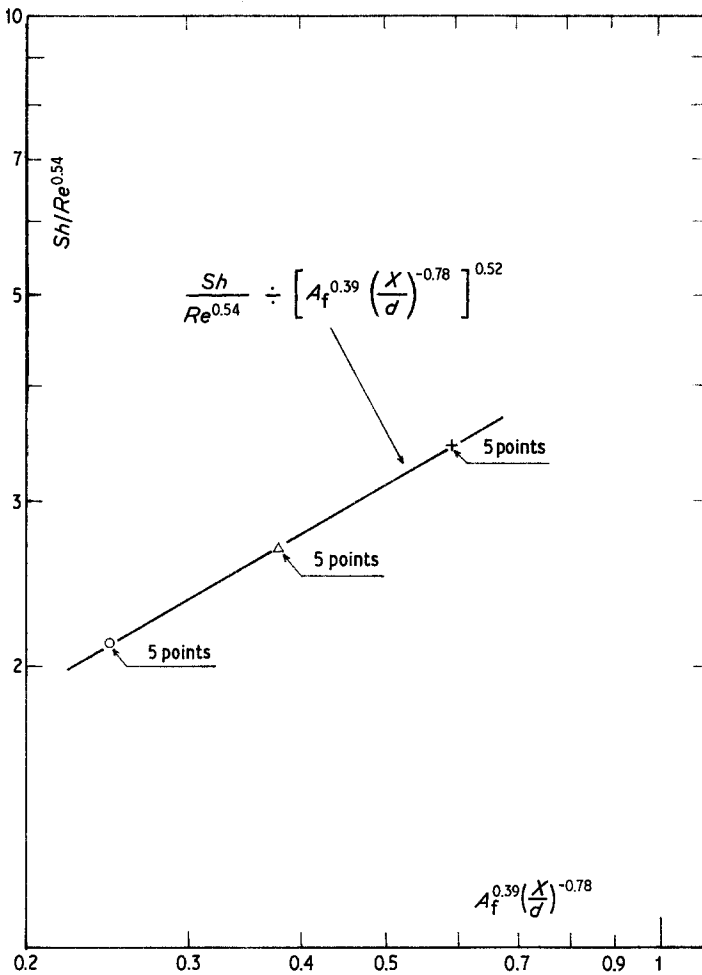

Fig. 10. Variations of $Sh/Re^{0.54}$ with $A_f^{0.39}(X/d)^{-0.78}$.

are always different from the others and are not considered in the analysis. The reasons is due to the high value of d (1.0 cm) in P15, compared with the height of the cylindrical nozzle (2 cm). In other words, the ratio height/diameter of the holes is too small to establish a hydrodynamic regime at the exit of the jet.

The influence of Re appears as $Re^{0.54}$ [20]. For $H/d = 4$ and electrode S7 it was established (Fig. 9) that $Sh/Re^{0.54}$ varies as $(X/d)^{-0.78}$ when $1.15\% < A_f < 3.72\%$ and $(A_f)^{0.39}$ when $3.7 < X/d < 6.64$. The reduced distance, X/d , and A_f vary at the same time according to Equation 1; then only one of these parameters could appear in a final correlation. However, in order to show the separate influence of X/d and A_f more clearly, Fig. 10 has been plotted, and it establishes that $Sh/Re^{0.54}$ is proportional to $[A_f^{0.39}(X/d)^{-0.78}]^{0.52}$. In both Figs. 9 and 10 there are multiple points ('5

points'); each multiple point is the arithmetic mean of 5 experimental values which differ by a maximum of 0.6%. Finally, the method of least squares was used to fit a best curve for the data points obtained (Fig. 11). The following empirical correlation is the result:

$$Sh = 0.43 Re^{0.54} Sc^{1/3} (X/d)^{-0.4} A_f^{0.2}. \quad (4)$$

For such a complex problem it is interesting to obtain in a relatively simple manner an empirical correlation. Obviously Equation 4 is restricted to one electrode (S7), one reduced height H/d and is deduced from results obtained by using a few distributors. Thus it cannot have a general character but simply demonstrates an ability to establish similar correlations for other experimental conditions.

Impinging multijets lead to high electrode/electrolyte mass transfer coefficients and appear

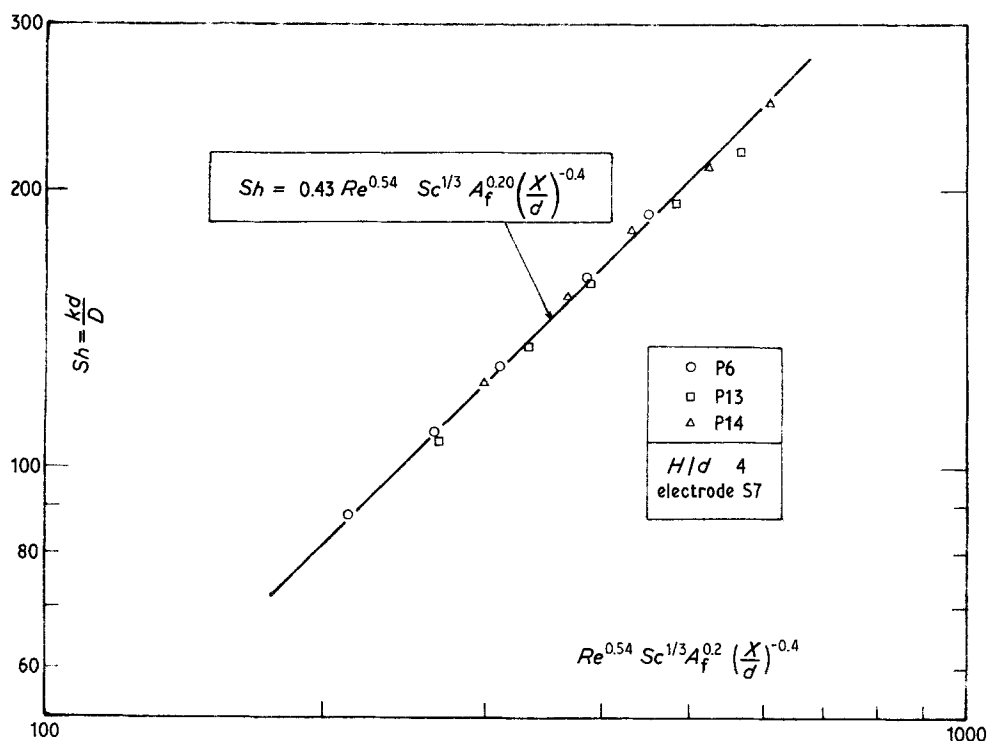

Fig. 11. Empirical correlation of the results.

interesting when the flow rates to be treated are small. The mode of perforation of the distributors has a direct influence on the mass transfer and has to be considered carefully. The relative ease of the electrochemical determination of wall to liquid mass transfer coefficients makes it preferable to extend the study reported here to other hydrodynamic conditions, rather than the transposition, by analogy, of empirical correlations deduced for heat transfer [13, 18]. Particularly, and this will be the aim of a further paper [22], it should be important to know the degree of uniformity of the spatial distribution of the local mass transfer coefficients.

5. Conclusions

The normal impingement of multijets of electrolyte leads to high limiting current densities at the electrode receiving the jets but many parameters have to be considered. By selecting conditions for which the jets conserve their definition, i.e. with short jet heights, it is possible to control the influence of the main parameters and to correlate the results very satisfactorily. Through the overall

measurements which have been carried out, it appears that the overall mass transfer coefficient is almost independent of the size of the electrode situated just below the multijets; out of the surface area bombarded by the jets, there is a pronounced decrease of the mass transfer coefficient.

Acknowledgement

This work was carried out within the program of scientific cooperation between France and Argentina. J. Nanzer gratefully acknowledge financial support from the French Government.

References

- [1] D. T. Chin and C. H. Tsang, *J. Electrochem. Soc.* **125** (1978) 1461.
- [2] F. Coeuret, *Chem. Eng. Sci.* **30** (1975) 1257.
- [3] C. J. Chia, F. Giralt and O. Trass, *Ind. Eng. Chem. Fundam.* **16** (1977) 28.
- [4] F. Giralt and O. Trass, *Can. J. Chem. Eng.* **53** (1975) 505.
- [5] F. Giralt and O. Trass, *ibid.* **54** (1976) 148.
- [6] M. Korger and F. Krizek, *Int. J. Heat Mass Transfer* **9** (1966) 337.

- [7] J. C. Bazan, S. L. Marchiano and A. J. Arvia, *Electrochim. Acta* **12** (1967) 821.
- [8] J. Yamada and H. Matsuda, *Electroanal. Chem. Interfac. Electrochem.* **44** (1973) 189.
- [9] B. Subba Rao, M. S. Krishna and G. J. V. Jagannadha Raju, *Periodica Polytechnica. Chem. Eng. (Budapest)* **17** (1973) 185.
- [10] H. Do Duc, *J. Appl. Electrochem.* **10** (1980) 385.
- [11] A. Tvarusko, Fluid flow in cells of plating lines for magnetic plated wire, *Plating* (October 1971).
- [12] B. R. Hollworth and R. D. Berry, ASME Paper no. 78-GT-117.
- [13] D. M. Kercher and W. Tabakoff, *ASME J. Eng. Power* **92** (1970).
- [14] R. A. Daane and S. T. Han, *Tappi* **44** (1961) 73.
- [15] S. J. Freidman and A. C. Mueller, *Inst. Mech. Engr. and ASME. Proceedings of the General Discussion on Heat Transfer*, London (1951) p. 138-142.
- [16] G. C. Huang, *ASME J. Heat Transfer* **85** (1963) 237.
- [17] R. Gardon and J. Cobonpue, *International Developments in Heat Transfer. Proceedings of the 2nd International Heat Transfer Conference ASME. New York* (1962) p. 454-460.
- [18] J. L. Chance, *Tappi* **57** (1974) 108.
- [19] P. Venkateswarlu and G. J. V. Jagannadha Raju, *Indian J. Technol.* **17** (1979) 1.
- [20] J. Nanzer, Thesis, University of Rennes I, France (July 1983).
- [21] F. Coeuret and A. Storck, *Informations Chimie (France)* no. 210 (Jan.-Feb. 1981) 121.
- [22] J. Nanzer and F. Coeuret in preparation.